

MSI-4260 PORT-A-WEIGH SPECIFICATIONS

The MSI-4260 crane scale is an ideal unit for heavy-duty applications. For heavy-duty applications requiring remote radio telemetry display and/or computer interface, MSI recommends specifying MSI-6260 Trans-Weigh.

CR= Crosby or equivalent.

* These dimensions also apply to 50/70/100,000 pound models with hook and shackles.

** Resolution subject to change for NIST and OIML approved units.

*** Ultimate overload - 490% of kg capacity.

**** Ultimate overload - 475% of lb capacity/430% of kg capacity.

***** Ultimate overload - 450% of kg capacity.

Specifications subject to change without notice.

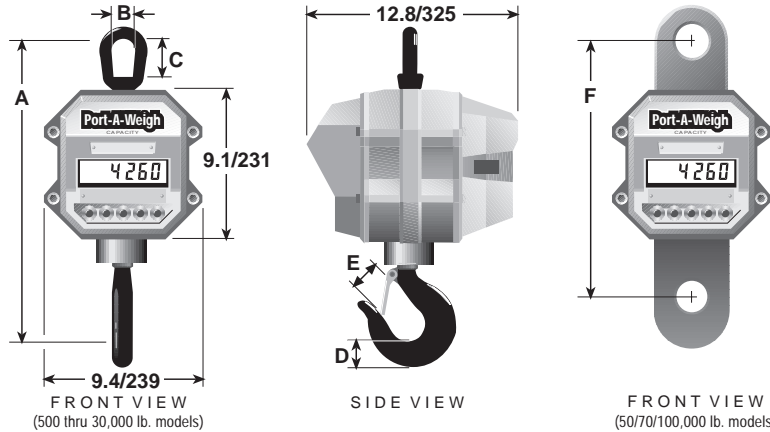

Note: Unit comes standard with top shackle & bottom swivel hook.

DIMENSIONS AND SPECIFICATIONS

CAPACITY	RESOLUTION**	A*	B*	C*	D*	E*	F	HOOK	EYE NUT OR SHACKLE	APPROX. SHIP WT.
500 lb	0.2 lb	18.3 in	2.25	3.06	1.44	1.34	-	3 ton	CR #7	53 lb
250 kg	0.1 kg	465 mm	57.1	77.7	37.0	34.0	-	Swivel	Eye Nut	24 kg
2,000 lb	1 lb	18.3 in	2.25	3.06	1.44	1.34	-	3 ton	CR #7	53 lb
1,000 kg	0.5 kg	465 mm	57.1	77.7	37.0	34.0	-	Swivel	Eye Nut	24 kg
5,000 lb	1 lb	20.5 in	2.50	3.50	1.81	1.69	-	5 ton	CR #8	62 lb
2,500 kg	0.5 kg	521 mm	64.0	89.0	46.0	42.9	-	Swivel	Eye Nut	28 kg
10,000 lb	2 lb	20.5 in	2.50	3.50	1.81	1.69	-	5 ton	CR #8	62 lb
5,000 kg	1 kg	521 mm	64.0	89.0	46.0	42.9	-	Swivel	Eye Nut	28 kg
20,000 lb	5 lb	28.5 in	4.00	6.25	2.59	2.25	-	10 ton	CR #11	105 lb
10,000 kg	2 kg	724 mm	101.6	159	65.8	57.2	-	Swivel	Eye Nut	47 kg
30,000 lb	10 lb	30.0 in	4.00	6.25	3.00	3.00	-	15 ton	CR #11	125 lb
15,000 kg	5 kg	762 mm	101.6	159	76.2	76.2	-	Swivel	Eye Nut	55 kg
50,000 lb	10 lb	41.0 in	5.00	6.00	3.66	3.63	15.0	25 ton	CR 25 ton	235 lb
25,000 kg	5 kg	1041 mm	127	152	93.0	92.0	381	Swivel***	Shackle #2130	106 kg
70,000 lb	20 lb	43.2 in	5.00	6.00	4.56	3.75	15.0	35 ton	CR 40 ton	270 lb
35,000 kg	10 kg	1097 mm	127	152	116	95.0	381	Swivel****	Shackle #2140	121 kg
100,000 lb	20 lb	51.6 in	5.75	6.65	5.06	4.25	16.25	CR 45 ton	CR 50 ton	420 lb
50,000 kg	10 kg	1311 mm	146	169	129	108	413	S1 Swivel*****	Shackle #2140	189 kg

CONSULT FACTORY FOR HIGHER CAPACITIES. SPECIFICATIONS SUBJECT TO CHANGE WITHOUT NOTICE.

STANDARD PRODUCT SPECIFICATIONS

Accuracy: Plus or minus 0.1% of applied load
Display: 5 digit, 1.0 in. (25 mm) high numeric LCD with photocell activated backlight and annunciator bars for net weight and low battery
Power: 12 Volt lead acid rechargeable battery (charger included)
Operating Time: LCD: 50 hours, LED: 25 hours between charges
Operating Temperature Range: 14° to +140° F (-10° to +60°C)
Enclosure: NEMA IV, anodized cast aluminum
Safe Overload: 200% of rated capacity
Ultimate Overload: 500% of rated capacity (except as noted)
Hook: Crosby thrust bearing swivel hook or equivalent

FUNCTION SWITCHES

ON/OFF: Turns unit ON or OFF and activates 5 minute automatic shut-off
LOCK: Overrides automatic shut-off and allows continuous operation until manually switched off
ZERO: Zeros applied load up to 100% of capacity (limited range with NIST or OIML option)
TARE SET: Tares applied load and displays weight in Net mode (up to 100% of scale capacity)
TARE CLEAR: Clears entered Tare Set value and returns the scale to Gross operating mode
NET/GROSS: Switches unit between NET and GROSS
POUNDS/KILOGRAMS: Internally selectable

OPTIONS AND ACCESSORIES

- NIST and OIML approved for use in commercial trade (contact factory for U.S. and International specs Class III & IIIL)
- Presettable Tare control
- Remote ON/ZERO Controller (not available on NIST or OIML approved units)
- Remote load cell input and summing
- Marine bulkhead (recommended for outdoor applications)
- Substitute shackle for bottom swivel hook (possible headroom loss reduction)
- Oversized top lifting eye or shackle
- AC/DC input power 115/230 VAC and 12 - 250 VDC (specify required voltage)
- EMI shield (recommended for applications above magnet)
- Heat shield for high temperature applications (contact factory for operating specifications)
- Factory Mutual Approved (intrinsically safe for use in hazardous environments): Class I, II, III
 DIV. 1, Group C, D, E, F, & G
 DIV. 2, Group A, B, C, D, & G
- LED digital display (0.8 inch high)
- 230 VAC battery charger



©1996 by Measurement Systems International
 Printed in U.S.A.
 PUB.119-02-90D

Distributor / Sales / Service & Calibration
Dillon/Quality Plus, Inc.
 3201 Corte Malpaso Unit 311
 Camarillo, CA. 93012
 Ph# 800-225-6543 Fax# 805-388-2735
 Email: sales@dqplus.com www.dqplus.com