

MDD

MANUAL TEST STAND

- 1kN capacity
- robust design
- high precision
- compact & portable
- handwheel operation
- tension & compression



Actuation testing

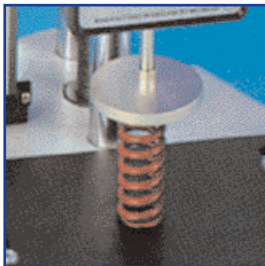

Spring testing



Shown with digital force gauge (not supplied)

- rugged and reliable
- holes for bench mounting
- accepts digital height scales

The MDD, combined with a Mecmesin force gauge, is ideal for low cost tensile and compression testing on the production floor or in laboratories.

Easy to use, the MDD is operated via a handwheel, which gives precise control of the crosshead, together with a lockable thumbwheel for fine adjustment.

The MDD is also fitted with a standard dovetail bracket for easy interchangeability of Mecmesin force gauges and loadcells. An optional height scale can be added for digital display of displacement and optional feet allow the MDD to be used horizontally.

versatile
easy-to-use
cost-effective

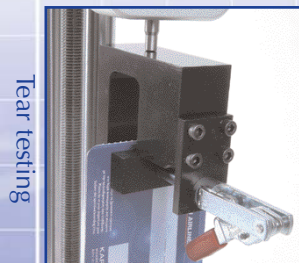

Tear testing

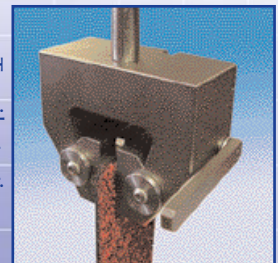

Tensile testing

Dimensions

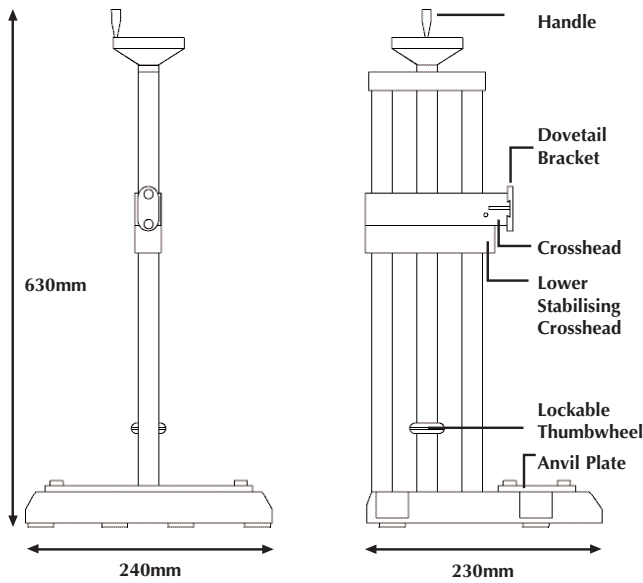

Optional Extras

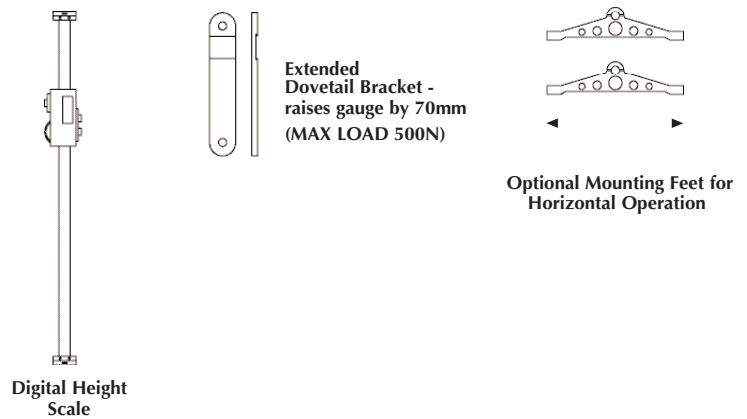

Mecmesin reserves the right to alter equipment specifications without prior notice.

Specifications

Model

MDD - Manual Direct Drive Test Stand

Crosshead travel (both directions)

2mm per handwheel revolution

Effective crosshead travel

380mm with AFG force gauge, but without accessories and height scale (400mm with BFG)
360mm with AFG/BFG force gauges and height scale, but without accessories

Maximum load

1000N/100kgf/220lbf

Weight

6kg

Optional Extras:

Height scale

0.01mm (0.0005in) resolution

Mounting feet

For horizontal operation



Dillon/Quality Plus, Inc.
Distributor/Sales/Service/Calibration
Email: sales@dqplus.com
Web: <http://www.testingmachine.com/>
Dillon/Quality Plus, Inc.
3501 N.E. Kimball Dr.
Kansas City, MO. 64161
Phone: 800-493-2263
Phone: 816-453-7600
FAX: 816-453-7677