

Series FB/PS/MF Push/Pull Mechanical Force Gauge

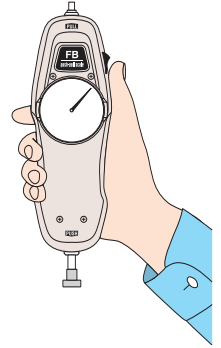

- Simple, rugged, virtually maintenance free
- Retains a high degree of accuracy for extended periods
- Ergonomic, heavy-duty metal construction
- No batteries needed
- Intrinsically safe in hazardous environments
- Capacity up to 100 lbs. (push and pull)
- Overload capacity 165 lbs on all ranges
- Tare ring
- Real time and peak mode
- Full set of accessories and carrying case included



The rugged construction of FB/PS/MF gauges will withstand industrial environments and yet retain calibration for extended periods. The ergonomic design makes it ideal for hand held use, or gauges can be mounted to test stands. The Zero-Tare ring allows you to compensate for measuring adapters and changes in measuring position, and the real time/peak hold selector switch allows you to observe transients or capture peaks.

Many ranges are available to cover all of your measurement needs. FB gauges are sold as kits complete with gauge, hard carrying case, five measuring tips (flat head, conical, chisel, notched, and small hook) as well as a 3 inch extension shaft.

All FB/PS/MF gauges are sold in kit form.



FB Ranges (Resolution) Accuracy: ±0.3% F.S.

Pounds	
Model	Capacity (Resolution)
FB-32oz	32oz (0.25 oz)
FB-80oz	80oz (1 oz)
FB-2	2 lb (0.02 lb)
FB-5	5 lb (0.05 lb)
FB-10	10 lb (0.1 lb)
FB-20	20 lb (0.2 lb)
FB-30	30 lb (0.25 lb)
FB-50	50 lb (0.5 lb)
FB-100	100 lb (1 lb)

Kilograms	
Model	Capacity (Resolution)
FB-1 kg	1 kg (10 g)
FB-2 kg	2 kg (20 g)
FB-3 kg	3 kg (25 g)
FB-5 kg	5 kg (50 g)
FB-10 kg	10 kg (100 g)
FB-20 kg	20 kg (200 g)
FB-30 kg	30 kg (250 g)
FB-50 kg	50 kg (500 g)

Newtons	
Model	Capacity (Resolution)
FB-10 N	10 N (0.1 N)
FB-20 N	20 N (0.2 N)
FB-30 N	30 N (0.25 N)
FB-50 N	50 N (0.5 N)
FB-100 N	100 N (1 N)
FB-200 N	200 N (2 N)
FB-300 N	300 N (2.5 N)
FB 500 N	500 N (5 N)

PS/MF Ranges (Resolution) Accuracy: ±0.2% F.S.; MF Accuracy: ±0.3% F.S.

Pounds	
Model	Capacity (Resolution)
PS-32oz	32oz (0.125 oz)
PS-80oz	80oz (1 oz)
PS-2	2 lb (0.01 lb)
PS-5	5 lb (0.025 lb)
PS-10	10 lb (0.05 lb)
PS-20	20 lb (0.1 lb)
PS-30	30 lb (0.125 lb)
PS-50	50 lb (0.25 lb)
PS-100	100 lb (0.5 lb)

Kilograms	
Model	Capacity (Resolution)
PS-0.5 kg	500 g (5 g)
PS-1 kg	1 kg (5 g)
PS-2 kg	2 kg (10 g)
PS-3 kg	3 kg (12.5 g)
PS-5 kg	5 kg (25 g)
PS-10 kg	10 kg (50 g)
PS-20 kg	20 kg (100 g)
PS-30 kg	30 kg (125 g)
PS-50 kg	50 kg (250 g)

Newtons	
Model	Capacity (Resolution)
PS-10 N	10 N (0.05 N)
PS-20 N	20 N (0.1 N)
PS-30 N	30 N (0.125 N)
PS-50 N	50 N (0.25 N)
PS-100 N	100 N (.5 N)
PS-200 N	200 N (1 N)
PS-300 N	300 N (1.25 N)
PS 500 N	500 N (2.5 N)

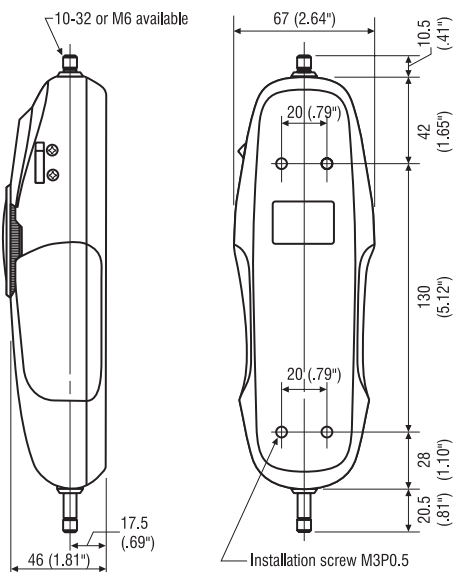

Specifications subject to change without notice.



Optional Handle OH-1

Fits FB/PS/MF gauges to facilitate the measurement of heavy loads. High quality steel with mounting screws.